

## SigmaBEND™ for Press Brakes

SigmaBEND brings many efficiencies used in sheet metal cutting to press brake technology. SigmaBEND maximizes the speed, quality and flexibility of bending processes with full 3-D simulation. Supported bending processes include air bending, die bending, and 3-point bending. Machine options such as angle measurement systems and lifting aids also are supported.

SigmaBEND operates from the user's viewpoint. While each sheet metal product may differ, the press brake configuration with the tooling is a fixed environment. This solution provides the ability to interactively change every programming parameter for ultimate control. The ability to program and verify bending operations offline frees up valuable machine time, improves first-off reliability and reduces manufacturing costs.

### Features

- Automatic recognition of bend information in a 2-D CAD file
- Direct 3-D CAD interface with Solid Works, Solid Edge, Inventor, Pro/Engineer, Catia, and One Space Designer/Sheet Advisor
- Automatic bend sequence, tool selection and finger stop placement
- Real-time simulation with collision detection
- Easy-to-use user interface for interactive editing of all bend parameters
- NC program in native controller code
- Automatic generation of full shop floor documentation with graphical illustrated set-up and bend sequence information
- 3-D graphical interface for simulation on the machine controller
- Integration with DNC for flawless data communication
- Extended interface with robot programming software

### Advantages

- Improve profitability by reduced waste costs
- Better planning results in on-time orders
- Data available when and where you need it

### Benefits

#### Speed

- Faster, more reliable programming away from machine tool
- Shorter programming time with CAD integration and automatic features
- Shorter set-up time with quick access to manufacturing information
- Better re-use of NC-programs

#### Quality

- Fewer design errors:
  - Centralized database
  - Integrated with the CAD/CAM system
- Check the process via realistic bending simulation
- Eliminate costly programming errors with collision check

#### Flexibility

- CAM system — direct switching between different press brakes
- Better production planning
- Less dependent on a specific person's knowledge with standardized programming

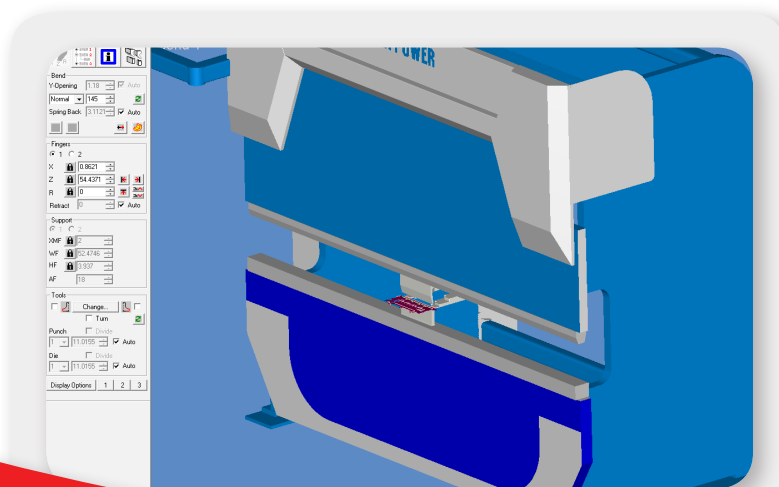

SigmaBEND simulation

### CONTACT

sales@sigmanest.com  
513.674.0005

www.sigmanest.com